

# TECHNICAL MANUAL SR601J/F

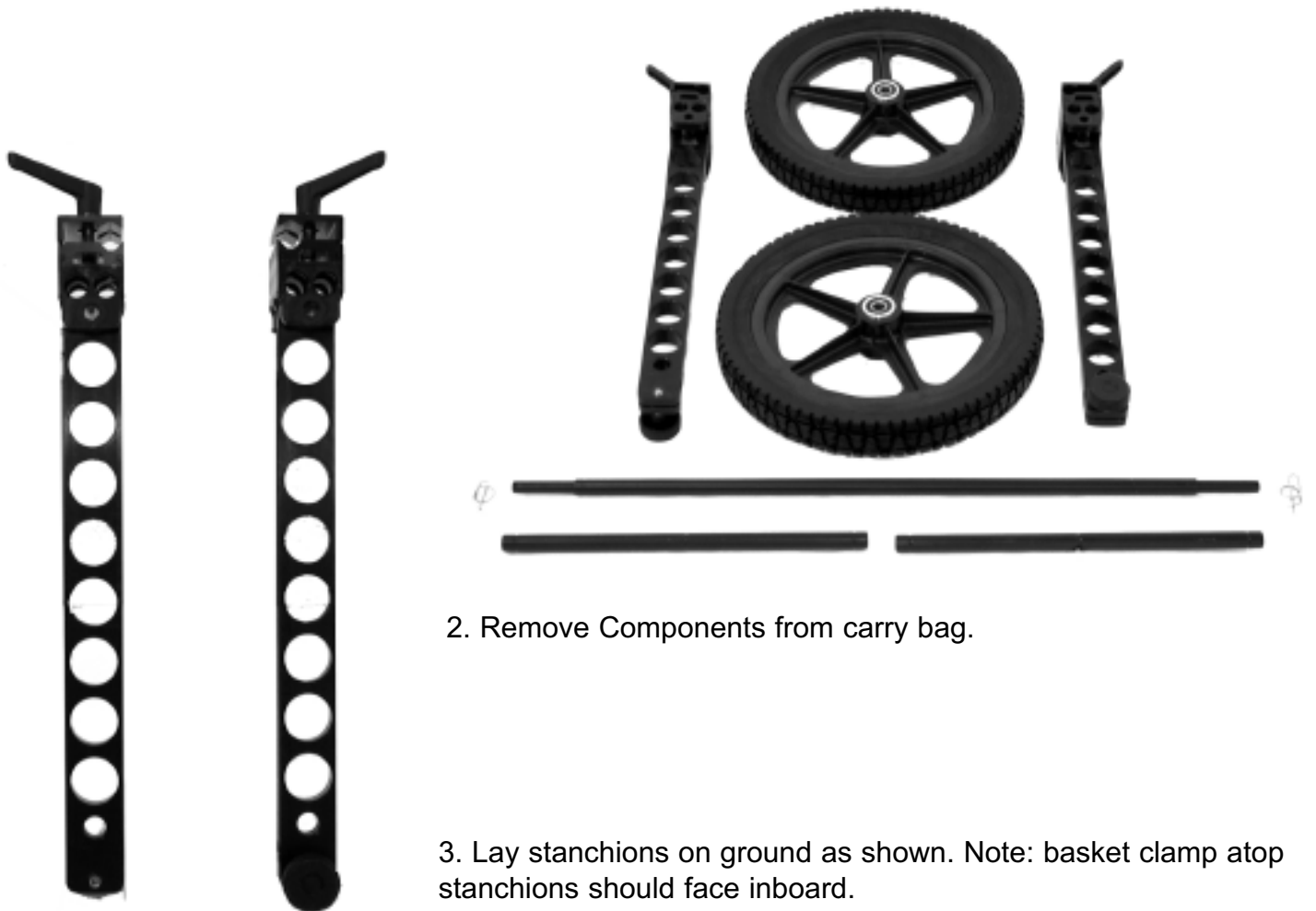

1. SR601J/F stored in bag.



2. Remove Components from carry bag.

3. Lay stanchions on ground as shown. Note: basket clamp atop stanchions should face inboard.



4. Insert Axle into Stanchions to groove on Axle and secure (Note: Axle is inserted into 3/4" hole.) →



5. Insert Kickstands into 3/4" hole located at bottom of stanchions directly over axle until engaged by stainless steel ball plunger (Approx. 1").

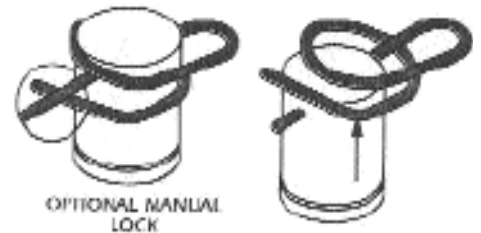

6. Install wheels onto Axle and insert Rue Pins to secure. To install Rue Pins push into hole at end of Axle and they will snap secure. To remove Rue Pins Lift end of pin which has slight bend and pull. To lock Rue Pin in place activate optional manual lock as illustrated.

7. Wheel assembly is now complete and ready for basket.



8. Place basket into clamps and secure (Note: Handles on clamps are ratchet type and can be set to any position by pushing down on the stainless steel button in the center of the handle). It is important to position wheels to balance the load being carried to reduce fatigue of personnel utilizing the SR601J/F. The recommended position of clamp on rail is shown in both pictures.

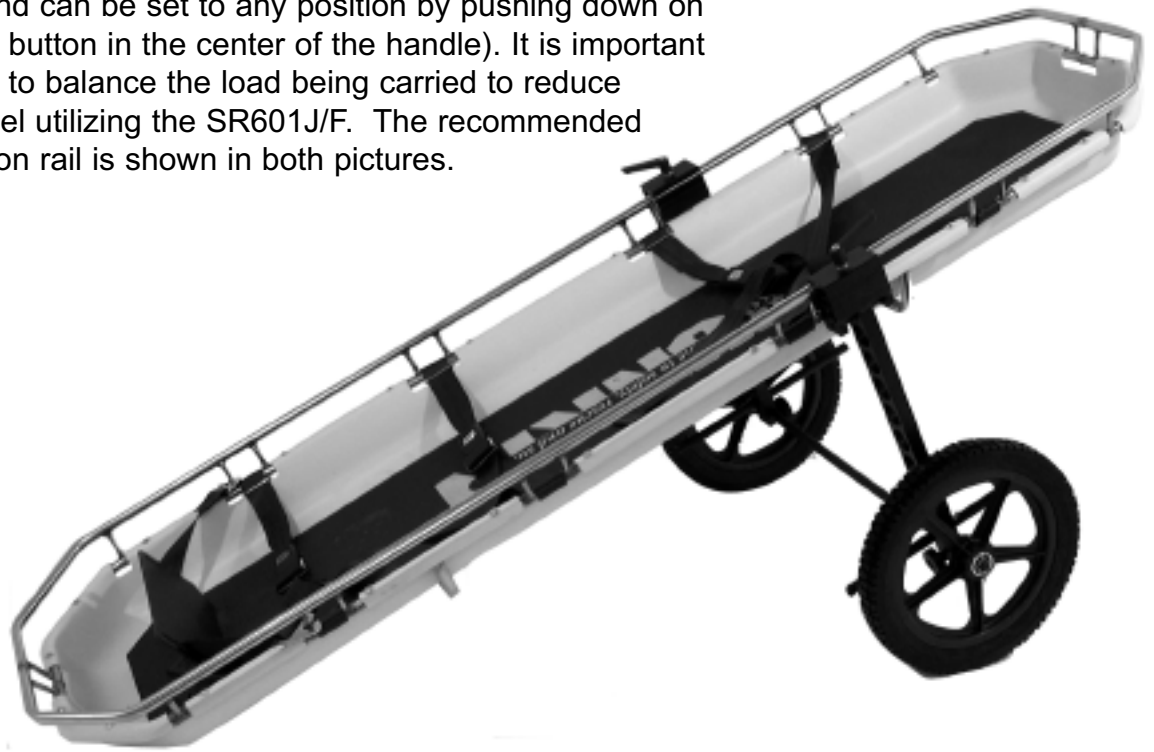

9. Unit with Junkin Basket ready to use.

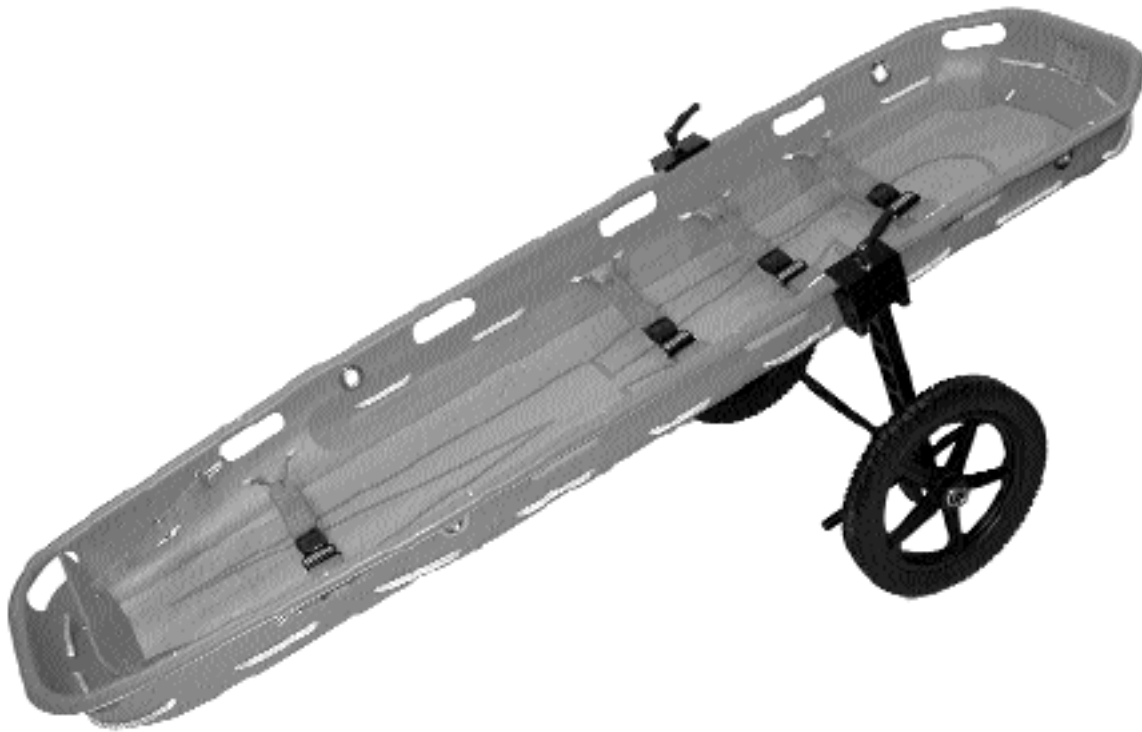

10. Unit with Ferno Basket ready to use.

# **PRODUCT SPECIFICATIONS**

Model :	SR601J/F	Fabric :	N/A			
Weight :	23 Pounds	Components :	Stainless Steel			
Capacity :	300 .lbs single axle					
Chassis :	6061-T6 Aluminum					
Wheels :	Fiberglass Reinforced Nylon			Height	Width	Length
Tires :	16" X 2" Micro-cellular Urethane	Collapsed Bagged :		3.5"	21"	33.5"
Bearings :	Sealed 440 Stainless Steel	Assembled / Overall :		27"	31"	16"
Finish :	Black Anodized	Transport Depth:		N/A	N/A	N/A
		Stretcher :		9"	22"	72"

## PARTS LIST

PART #	QTY	DESCRIPTION	MATERIAL
<b>NCO5017</b>	<b>2</b>	<b>STANCHION ASSEMBLY</b>	<b>6061-T6 ALUMINUM</b>
6000110	2	BALL PLUNGER	STAINLESS STEEL
6000117	2	WASHER	STAINLESS STEEL
NCO5006	2	STANCHION KNOB	POLYMER
<b>NCO0048</b>	<b>2</b>	<b>SUPPORT TUBE</b>	<b>6061-T6 ALUMINUM</b>
<b>NCO5038(J) or NCO5037(F)</b>	<b>2</b>	<b>BASKET CLAMP ASSEMBLY</b>	<b>6061-T6 ALUMINUM</b>
6000111	4	CAP SCREW	STAINLESS STEEL
6000112	4	LOCK WASHER	STAINLESS STEEL
<b>NCO5039(J) or NCO5026(F)</b>	<b>1</b>	<b>AXLE ASSEMBLY</b>	<b>6061-T6 ALUMINUM</b>
<b>6000109</b>	<b>2</b>	<b>RUE PIN</b>	<b>STAINLESS STEEL</b>
<b>NCO5025</b>	<b>2</b>	<b>WHEEL ASSEMBLY</b>	<b>NYLON</b>
6000133	4	BEARING	STAINLESS STEEL
6000134	2	TIRE	URETHANE
		<b>CANVAS COMPONENTS</b>	
2029810	1	BAG-CARRY	1000 DENIER NYLON

# PARTS IDENTIFICATION

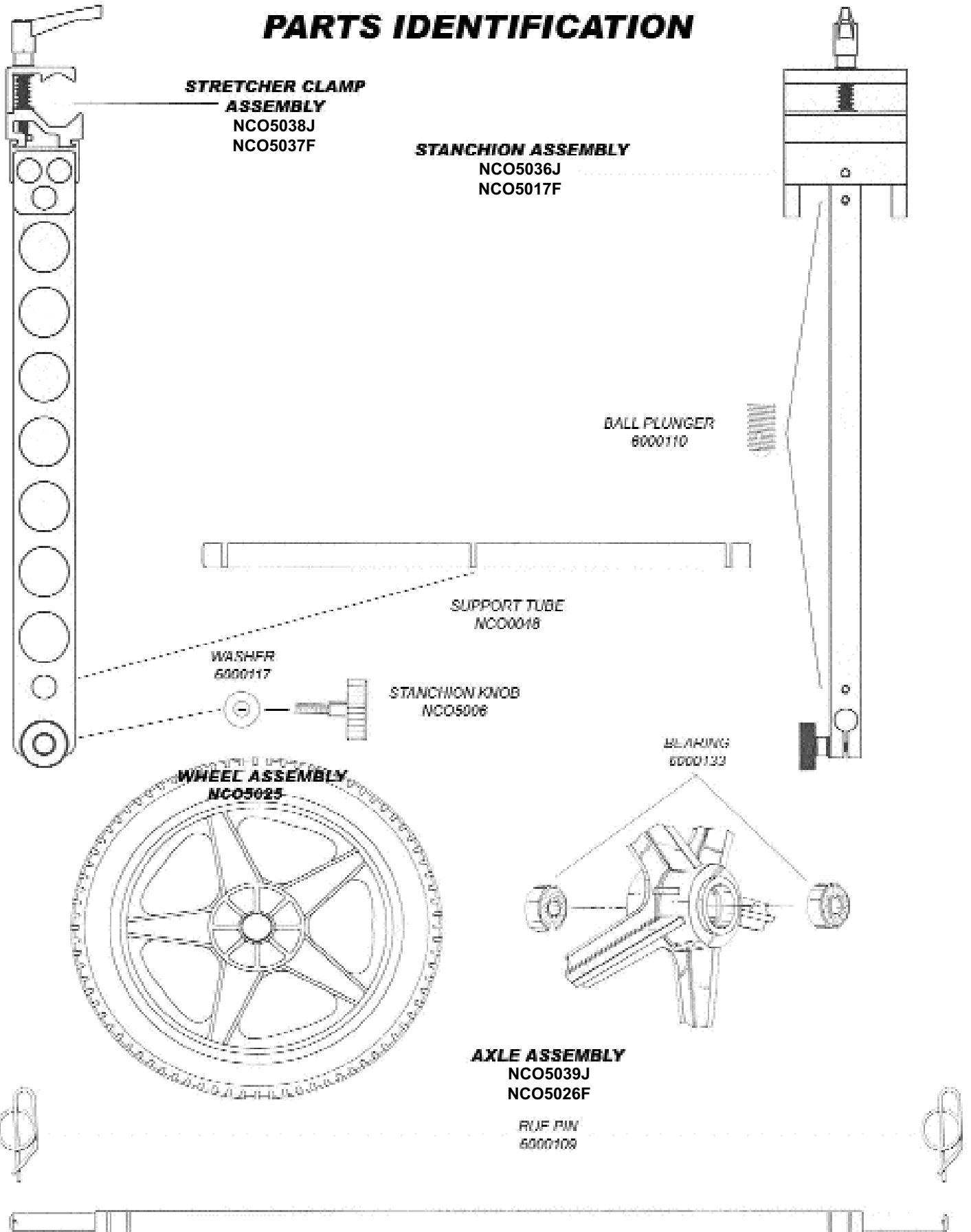

**PATENTS 6,142,491 6,164,671, 6,270,092**

# **LIMITED WARRANTY**

Charlie's Horse, a product of North Coast Outfitters Ltd., warrants each new Charlie's Horse according to the following terms.

This warranty extends for the lifetime of Charlie's Horse as long as the original retail purchaser owns it. This warranty extends to the original retail purchaser only and commences on the date of original retail purchase. Accordingly, this warranty is not transferable to any subsequent purchasers.

Any part of Charlie's Horse manufactured or supplied by North Coast Outfitters Ltd. and found in the reasonable judgment of North Coast Outfitters Ltd. to be defective in material or workmanship will be repaired or replaced by North Coast without charge for parts or labor.

Charlie's Horse including any defective part must be returned to North Coast Outfitters Ltd. The owner will pay for the expense of returning Charlie's Horse to North Coast Outfitters, Ltd. and the expense of returning it back to the owner after repair or replacement. North Coast Outfitters Ltd. responsibility in respect to warranty claims is limited to making the required repairs or replacements within 60 days, and no claim of breach of warranty shall be cause for cancellation or rescission of the contract of sale of any Charlie's Horse.

Proof of purchase will be required by North Coast Outfitters Ltd. to substantiate any warranty claim. North Coast Outfitters Ltd must perform all warranty work.

If Charlie's Horse is used commercially for such purposes as rental or other income-producing activities, then this warranty is limited to one (1) year from the date of original retail purchase. Military use is considered commercial use.

This warranty does not cover any Charlie's Horse that has been subject to misuse, neglect, negligence, or accident, or that has been operated in any way contrary to the operating instructions. The warranty does not apply to any damage to Charlie's Horse that is the result of improper maintenance or to any parts that have not been assembled or installed as specified in assembly instructions. The warranty does not cover any Charlie's Horse that has been altered or modified so as to adversely affect the product's operation, performance or durability, or that has been altered or modified to change its intended use. In addition, the warranty does not extend to repairs made necessary by normal wear, or by the use of parts or accessories which are either incompatible with Charlie's Horse or adversely affects its operation, performance or durability.

North Coast Outfitter's Ltd. reserves the right to change or improve the design of any Charlie's Horse without assuming any obligation to modify any Charlie's Horse previously manufactured.

ALL IMPLIED WARRANTIES ARE LIMITED IN DURATION TO ONE (1) YEAR FROM DATE OF PURCHASE. ALL IMPLIED WARRANTIES, INCLUDING MERCHANTABILITY, AND FITNESS FOR A PARTICULAR PURPOSE, OR OTHERWISE, ARE DISCLAIMED IN THEIR ENTIRETY AFTER ONE YEAR. THERE ARE NO WARRANTIES, WHICH EXTEND BEYOND THE DESCRIPTION ON THE FACE HEREOF.

NORTH COAST OUTFITTERS LTD. OBLIGATION UNDER THIS WARRANTY IS STRICTLY AND EXCLUSIVELY LIMITED TO THE REPAIR OR REPLACEMENT OF DEFECTIVE PARTS AND NORTH COAST OUTFITTERS, LTD. DOES NOT ASSUME OR AUTHORIZE ANYONE TO ASSUME FOR THEM ANY OTHER OBLIGATION.

SOME STATES DO NOT ALLOW LIMITATIONS ON IMPLIED WARRANTIES, SO THE ABOVE LIMITATION MAY NOT APPLY TO YOU.

NORTH COAST OUTFITTERS LTD. ASSUMES NO RESPONSIBILITY FOR INCIDENTAL, CONSEQUENTIAL OR OTHER DAMAGES INCLUDING, BUT NOT LIMITED TO, EXPENSE OF RETURNING CHARLIE'S HORSE TO NORTH COAST OUTFITTERS, LTD. AND THE EXPENSE OF RETURNING IT BACK TO THE OWNER, TELEPHONE CHARGES, RENTAL OF A LIKE PRODUCT DURING THE TIME OF WARRANTY SERVICE IS BEING PERFORMED, TRAVEL, LOSS OR DAMAGE TO PERSONAL PROPERTY, LOSS OF REVENUE, LOSS OF USE OF CHARLIE'S HORSE, LOSS OF TIME OR INCONVENIENCE.

SOME STATES DO NOT ALLOW THE EXCLUSION OR LIMITATION OF INCIDENTAL OR CONSEQUENTIAL DAMAGES, SO THE ABOVE LIMITATION OR EXCLUSION MAY NOT APPLY TO YOU.

This warranty gives you specific legal rights and you may also have other rights, which vary from state to state.

NORTH COAST OUTFITTERS LTD.  
P.O. Box 994  
Hampton Bays, New York 11946

# CHARLIE'S HORSE DEPLOYMENT SYSTEM

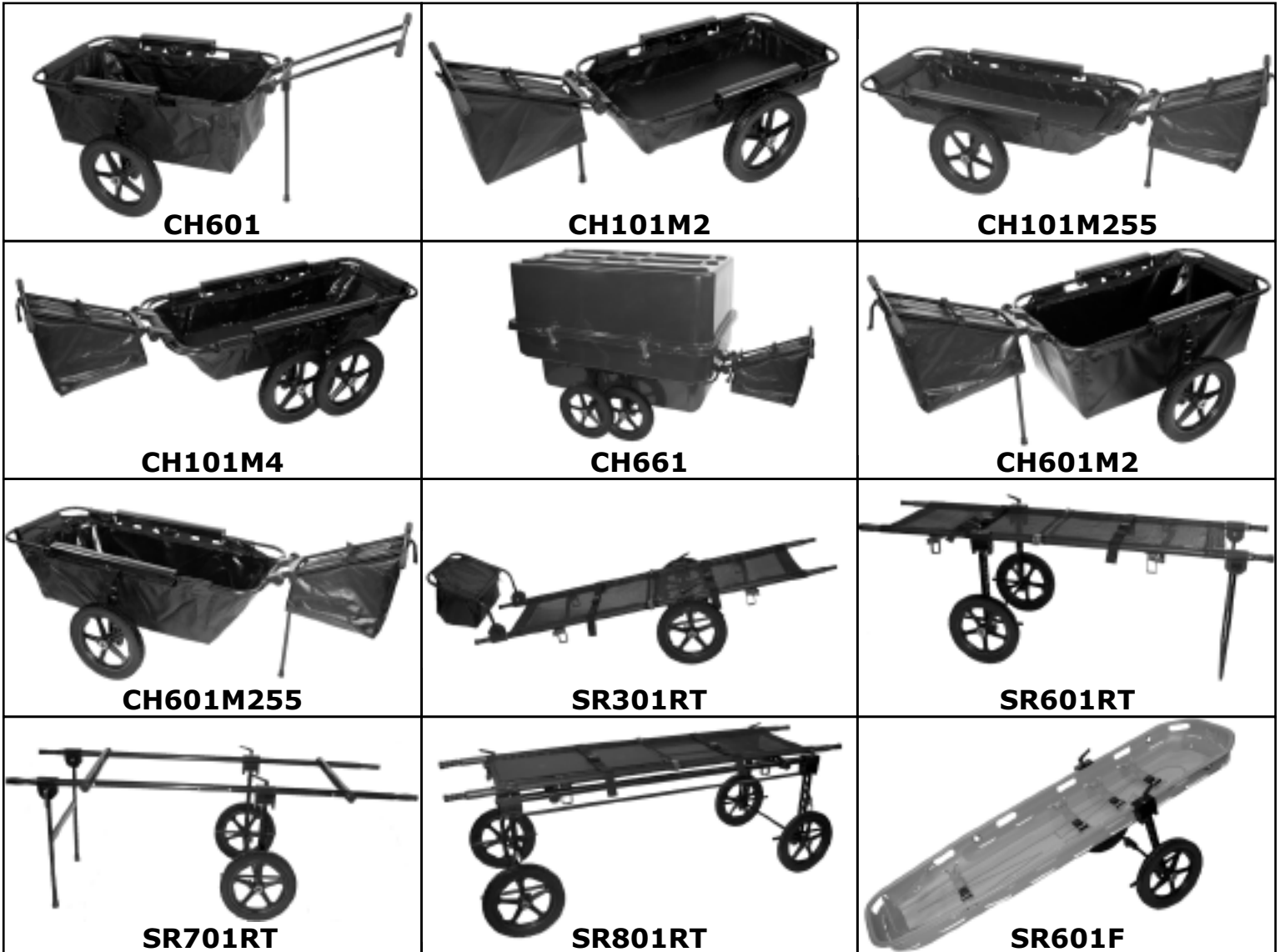

THE CHARLIE'S HORSE® LINE OF PRODUCTS, MANUFACTURED BY NORTH COAST OUTFITTERS LTD., IS A FULLY INTEGRATED TRANSPORT SYSTEM WITH COMPLETE INTERCHANGEABILITY OF COMPONENTS DESIGNED TO BE MISSION ADAPTABLE, NOT MISSION SPECIFIC. EQUIPMENT STORES WITHIN A COMPACT CARRY BAG AND ASSEMBLES IN MINUTES WITHOUT TOOLS. WHEN DEPLOYED AS A COMPLETE SYSTEM, CHARLIE'S HORSE® REDUCES MANPOWER REQUIREMENTS 40% WHILE INCREASING THEIR EFFECTIVENESS.

**[www.charlieshorse.com](http://www.charlieshorse.com)**

**GSA CONTRACT: GS-07F-0244L**

**TELEPHONE : 631-728-5485**

FOR CATALOG AND PRICING PLEASE COMPLETE AND RETURN.

**NAME:** \_\_\_\_\_

**POSITION:** \_\_\_\_\_

**ORGANIZATION:** \_\_\_\_\_

**TELEPHONE:** \_\_\_\_\_

**ADDRESS:** \_\_\_\_\_

**E-MAIL:** \_\_\_\_\_

\_\_\_\_\_  
\_\_\_\_\_  
\_\_\_\_\_

**WEB SITE:** \_\_\_\_\_

**NORTH COAST OUTFITTERS LTD.  
P.O. BOX 994  
HAMPTON BAYS, NY 11946**